



Retain this instruction for future reference.

Important: READ THESE INSTRUCTIONS CAREFULLY BEFORE CLEANING.

This guide features instructions to maintain your grill. Guidelines are provided for how to clean your grill before and after each use. A section is also included on how to deep clean your grill twice a year (or as needed).

A qualified professional barbecue repair/service technician is recommended to perform the deep clean.

WARNINGS AND SAFETY INFORMATION

- **After cleaning the grilling surface with a grill brush, wipe down the surface with a clean rag and inspect all surfaces to be sure grill brush bristles have not become dislodged from the brush and are on the grids or unit. Grill brush bristles can present a hazard if they are transferred to food cooking on the grill and are accidentally consumed.**
- Wear appropriate gloves, safety glasses, and clothes appropriate for the clean.
- Your grill requires regular cleaning and maintenance to ensure proper operation, appearance, and safety.
- A clean and well maintained grill prevents the risk of grease build-up and grease fires.
- Clean your grill before and after each use as instructed in this guide.
- A deep clean of the entire grill and all its components should be performed twice a year (or as needed depending on use). Refer to this guide.
- The burner ports and carry-over ports/slots (if applicable) MUST be kept clean to ensure proper ignition and operation. See BURNERS section.
- **For Fire Magic Aurora and Echelon grills, a Flame Arrester Kit (24177-05) is required for each burner.** (The kit prevents grease fire damage to your grill wiring.) If not already equipped, contact your dealer to obtain. The DEEP CLEANING - REINSTALLATION section of this manual addresses the kit.
- **Prior to servicing or cleaning make sure the unit is completely cool, the control knobs are turned to the OFF position, the gas supply is shut off, the light switch is off, and the power supply is disconnected (as applicable and unless otherwise stated). Verify proper operation after servicing or deep cleaning.**
- DO NOT spray any cleaner or liquids on the grill when hot.
- An optional [protective cover](#) will protect your grill when not in use. Contact your dealer for ordering information.
- **Specific types of cleaning agents, cloths, and abrasive pads are recommended in these instructions. The use of other types may cause damage to your grill.**
- **WHEN USING CLEANING PRODUCTS TO CLEAN YOUR GRILL, CLOSELY FOLLOW THE INSTRUCTIONS SUPPLIED WITH THE PRODUCTS.**
- **Always wipe/brush with the grain of the stainless steel when cleaning.**

ITEMS NEEDED

Items needed to clean before each use:

- Soft cleaning cloths
- Rubber gloves

Items needed to clean after each use:

- The above items, plus:
- [Copper scrubbing pads](#)
- Grill brush
- Wash bucket filled with soapy water solution

Items needed for deep clean:

- All above items, plus:
- [Saw blade](#)
(applies to cast stainless steel burners, only available from your dealer, see below for details)
- [Drill bits \(2 mm\)](#)
(applies to cast stainless steel burners, see below for details)
- [Large foil pans](#) or a 5 gallon bucket
(to soak burners)
- [Grill cleaner](#)
- Non-corrosive oven/grill cleaner
(for porcelainized (black) surfaces only, cleaner must be non-corrosive)
- Stainless steel cleaner
- Power drill (applies to cast stainless steel burners)
- Needle nose pliers
- Degreaser
- Safety glasses
- Glass cleaner (window models only)
- WD-40™ (applies to cast stainless steel burners)
- Putty knife
- Disposable drop cloths (or newspaper)

Most of the tools can be purchased from your local hardware store (except saw blade, see below).

For Fire Magic grills with cast stainless steel burners, the following kits are available to assist in cleaning.

- [MK-1: Burner Maintenance Kit](#)
(includes saw blade and 2mm drill bits)
- [MCK-1: Grill Maintenance Kit](#)
(includes saw blade, 2mm drill bits, copper pads, cleaning cloths, foil pans, and dielectric grease.)

BEFORE AND AFTER EACH USE

BEFORE EACH USE

Inspect and clean the exterior surfaces of the unit: With a cool grill, clean any dust, grease, splatter, or spills as needed with a damp clean cloth.

AFTER EACH USE

1. **Perform a burn-off and clean the [cooking grids](#):** Operate the grill on high with the hood closed for 15 minutes to burn-off food and grease and allow for an easier cooking grid clean. Then turn OFF the grill and use a grill brush to clean the cooking grids of all residue. Wear protective gloves and use caution around hot surfaces. Once the grill is cool, wipe down the grids with a clean rag and inspect all surfaces to be sure grill brush bristles have not become dislodged from the brush and are on the grids or unit.
2. **Check and clean your drip tray:** When the grill is cool, carefully remove the drip tray and dispose of contents appropriately. If tray is equipped with a liner, dispose of the liner (select Fire Magic models only). Clean tray in a soapy water solution if needed. For tough deposits, a copper pad can be used. Rinse and dry completely. Replace a new liner (if applicable) and insert the tray back into the grill.
3. **Charcoal grills only:** When the grill is cool, carefully remove the additional drip tray (left side), dispose of contents appropriately, and clean if needed. Next, remove the charcoal tray on the interior of the grill (left side), empty any ash into a fireproof container, and clean if needed.
4. **Cover your grill:** Once the grill is dry and cool, cover your grill with a [protective cover](#) (see following section).

PROTECTING YOUR GRILL

An optional [protective cover](#) will protect your grill when not in use. Install the cover on a cool and dry grill. **DO NOT** cover a damp grill. During high humidity or after rainy conditions, remove the cover to dry trapped moisture if present. (If the cover is installed over a damp grill it can cause surface rust.)

Ensure that the **INSIDE** of the cover is DRY before putting it back on the grill.

DEEP CLEAN

BEFORE YOU BEGIN

APPLIANCE MUST BE COMPLETELY COOL WHEN CLEANING.
(NEVER SPRAY ANY CLEANER OR LIQUIDS ON THE APPLIANCE WHEN HOT.)

To assist in the cleaning process, it is recommended that the following preparation guidelines be observed:

- Obtain all required tools & dress appropriately, including safety glasses and rubber gloves.
- Obtain the [Flame Arrester Kit\(s\)](#) if applicable/needed.
- Use a disposable drop cloth or newspaper to set up a cleaning station.
(for cleaning dirty components)
- Mix a soapy water solution in a wash bucket.
- Use a disposable drop cloth or newspaper to set up a drying station.
(for drying and storing clean components)
- Prep the power drill by installing a 2 mm drill bit into your drill (if applicable).

INTERIOR COMPONENTS

Note: A "dry scrub" directly in the grill is recommended prior to removing each component (to reduce later clean up). Use a grill brush or putty knife.

1. With a cool grill, remove all interior components found in the grill. This will include some or all of the following:
 - rotisserie rod assembly, warming rack, [cooking grids](#), heatzone separators, [flavor grids](#)/vaporizer panels, backburner cover, infrared cover, charcoal trays/baskets (empty any ash into a fireproof container)

Refer to the owner's manual for details on removal if needed.

Details on cleaning the burners are found on the next page.

2. Using a clean soft cloth and glass cleaner, gently wipe down backburner cover and set aside (if applicable).
Do not clean the cover with abrasive tools or cleaners.
3. Use a grill brush to remove all excess grease and food deposits from both sides of cooking grids. Then wipe down the grids with a clean rag and inspect them to be sure grill brush bristles have not become dislodged from the brush and are on the grids.
4. Clean all components in a soapy water solution. For tough deposits, a copper pad can be used. Always wipe with the grain. Use caution on sharp edges.

Note: Allowing the components to soak prior to scrubbing will make cleaning easier.

5. Rinse and dry completely, and set aside.

BACKBURNER (if equipped)

The backburner is self cleaning (by way of its high temp operation) and will not require manual cleaning.

DEEP CLEANING (cont.)

BURNERS

Your grill is equipped with either tubular or cast stainless steel burners (see Fig. 4-1). Refer to the owner's manual for details on removal, and clean per the appropriate section below.

If you clean the burners with a grill brush, wipe down the burners with a rag and inspect them to be sure grill brush bristles have not become dislodged from the brush and are on the burners.

Note: Set any infrared burner(s) aside for later reinstallation. Infrared burners are self cleaning (by way of a post-cook, 5 minute burn off period) and will not require manual cleaning.

Tubular Burners

Remove all burners from the grill. Take one burner and lightly scrub it with a copper pad or grill brush (see Fig. 4-2). Be sure that all ports are open and clear of foreign material. Repeat for each burner.

Cast Stainless Steel Burners

1. Remove all burners from the grill. Mix a solution of liquid dish soap (with degreaser) and water in several foil pans. A 5 gallon bucket may also be used. Place burners into solution and allow to soak overnight (for at least 14 hours). See Fig. 4-3, A.
2. Take one burner and thoroughly scrub using a copper pad or grill brush (see Fig. 4-3, B).
3. Properly secure one burner so that it does not move during cleaning (a vice is recommended). See Fig. 4-3, C.
4. Spray burner ports and carry-over slots with WD-40™ (or other equivalent product) to assist in cleaning and lubricating the drill bit. Let sit for 5 minutes.
5. Use previously prepped power drill to **CAREFULLY** drill both exterior and interior ports (from exterior sides) until they are open and clear of foreign material (see Fig. 4-3, C). To prevent bit breakage, keep drill aligned with burner port while drilling and bring drill up to speed before insertion.

Note: Interior ports are drilled out at same time; they are in line with exterior ports (see Fig. 4-3, C).

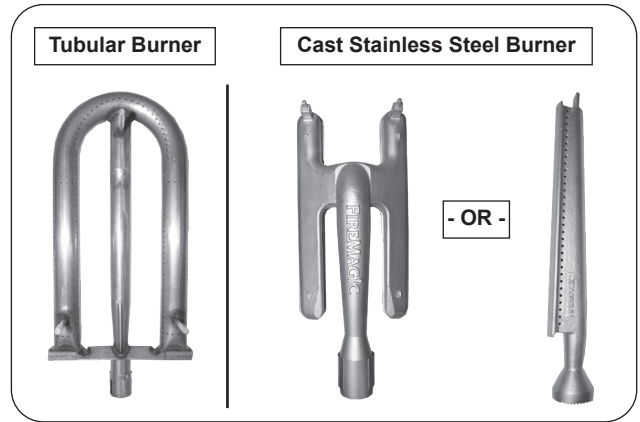

Fig. 4-1 Burner types



Fig. 4-2 Tubular burner cleaning

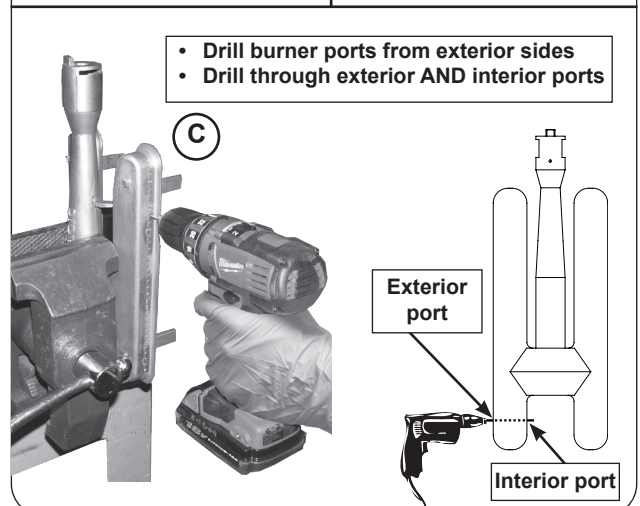
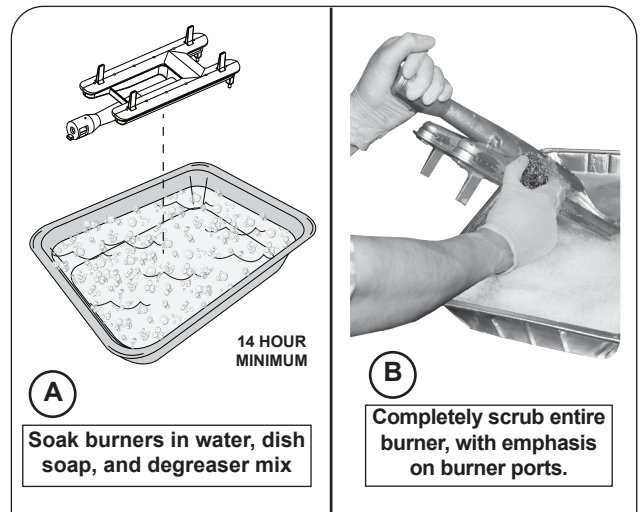

Fig. 4-3 Cast stainless steel burner cleaning

DEEP CLEANING (cont.)

- Slide saw blade into each of 4 carry-over slots on front and rear of burner, until the slots are open and clear of foreign material (see Fig. 5-1 and Fig. 5-2).

Note: **THE FIRE MAGIC SAW BLADE MUST BE USED.** Any other tools will not clean the carry-over slots correctly. **BE CAREFUL WHEN HANDLING THE SHARP BLADE AT ALL TIMES.** Contact your dealer to order.

- Repeat process for each burner.
- Finish burner cleaning by rinsing each burner completely. Ensure that burner inlets are clear of any debris. Drain excess water out of burners and set aside.

INTERIOR LINER

- Remove any baffles found at bottom of grill interior and clean as needed.
- Use a stainless steel putty knife to remove any grease and food deposits. Then use a [grill cleaner](#) and a copper pad to scrub the liner. Follow instructions provided with the grill cleaner.
- Wipe down the entire surface of the liner with a wet, clean, heavy-duty rag. Remove all cleaner.

MAGIC VIEW WINDOW (if equipped)

Clean interior of window by scrubbing it with copper pad soaked in wash bucket solution. A heavy duty oven cleaner such as Easy-Off® may be used. Wipe down with a damp clean cloth. Remove all cleaner.

DRIP TRAY & SMOKER DRAWER (if applicable)

- Carefully remove the drip tray and dispose of contents appropriately. If tray is equipped with a liner, dispose of the liner (select Fire Magic models only). Clean as needed. Rinse and dry completely. Replace a new liner (if applicable) and insert the tray back into the grill.

Note: Charcoal grills will have an additional charcoal drip tray. Remove and clean as needed.

- Older Fire Magic Echelon models may have a smoker drawer. If equipped, remove from grill, empty any ash into a fireproof container, and clean as needed.

REINSTALLATION

Prior to reinstallation, if your Fire Magic Aurora or Echelon grill is not already equipped with Flame Arrester Kits #24177-05 (see Fig. 5-3), install them per the instructions supplied with the kit. Contact your local dealer.

Reinstall all components removed during the cleaning process.

Note: When reinstalling each burner, it is critical to the continued safe functioning of the burner that the orifice is centered and completely inside burner gas conduit. Be sure to replace any burner pins or flash tubes that were removed.

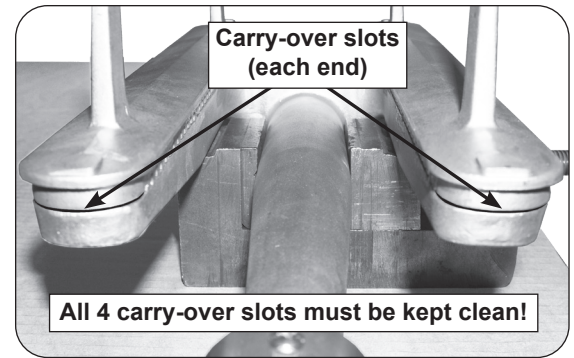

Fig. 5-1 Carry-over slots detail

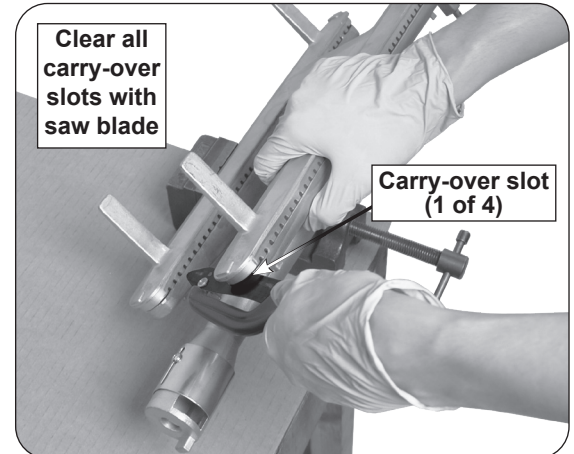

Fig. 5-2 Saw out carry-over slots



Fig. 5-3 Install flame arrester kits

EXTERIOR OF GRILL

Porcelainized (black) surfaces: Use a [non-corrosive oven/grill cleaner](#) (or a soapy water solution) and a clean cloth to remove grease and dirt. Rinse and dry completely.

Stainless steel surfaces: Use a [grill cleaner](#) (or a soapy water solution) and a clean cloth to remove grease and dirt from the outside of the grill. For tough deposits, a copper pad can be used. Always wipe with the grain. Rinse and dry completely. Then follow up with a [stainless steel cleaner](#) and a clean cloth. To clean the magic view window (if equipped), use a quality brand glass cleaner. DO NOT use other cleaners or chemicals.

If this routine cleaning is not performed, the stainless steel may become dull and develop surface rust (due to use and atmospheric conditions). If left uncleaned, significant damage and pitting may occur.

Important: DO NOT use steel wool, any other metal tools, or any other cleaners/chemicals to clean the exterior other than recommended above. Such items promote rust.

Note: Due to the nature of stainless steel, temperatures produced by the grilling process will cause discoloration. This can be reduced by routine cleaning.

ACCESSORY BURNERS (stand alone grills only)

If your stand alone grill is equipped with an accessory burner (side burner, power burner, etc.), clean the cooking grid and interior liner as needed (based on the previous info in this guide.)

ALL CONNECTIONS - DIELECTRIC GREASE

Dielectric grease is to be applied any time that any wire(s) are disconnected. [MCK-1](#) kits include this grease. Although this cleaning guide does not require any wire disconnections, refer to the instructions below if any disconnections have been made in the past, or are made in the future.

Prior to re-connecting any wires, apply a small amount of dielectric grease to the male connector as shown in Fig. 6-2, then make the connection.

This procedure should be done every time that a wire connection is made.

BURN-OFF

Operate your grill for 5 minutes to burn off any chemical/cleaner remnants (on the interior surface) left from the cleaning procedures addressed in this guide.



Fig. 6-1 Wipe with grain

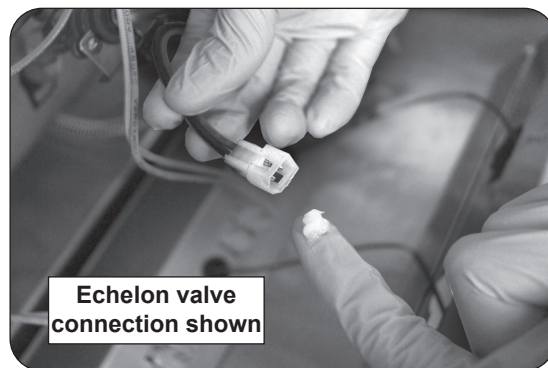

Fig. 6-2 Dielectric grease application

FOR ENVIRONMENTS HIGH IN SALT, CHLORIDE, OR OTHER CORROSIVE CHEMICALS

When this grill is installed in a corrosive environment such as near the ocean (salt air), poolside (chlorine and/or pool chemicals) or any other location with exposure to high salt/chloride content or corrosive chemicals/solutions, it will be more susceptible to corrosion and MUST be maintained/cleaned more frequently.

- DO NOT store any corrosive chemicals (chlorine, hydrochloric acid, fertilizer, etc.) near your stainless steel grill.
- DO NOT allow any corrosive materials (masonry dust, debris, etc.) to settle on your stainless steel grill.
- These environments, chemicals, and materials may cause the 304 stainless steel to develop surface rust and consequently pitting. Under these conditions the grill exterior MUST be cleaned at least monthly. Inspect your grill often and clean accordingly.