



# AURORA

## INFRARED BURNER KIT

### INSTRUCTIONS

(Spark Ignition)

Model # 3049  
# 3051

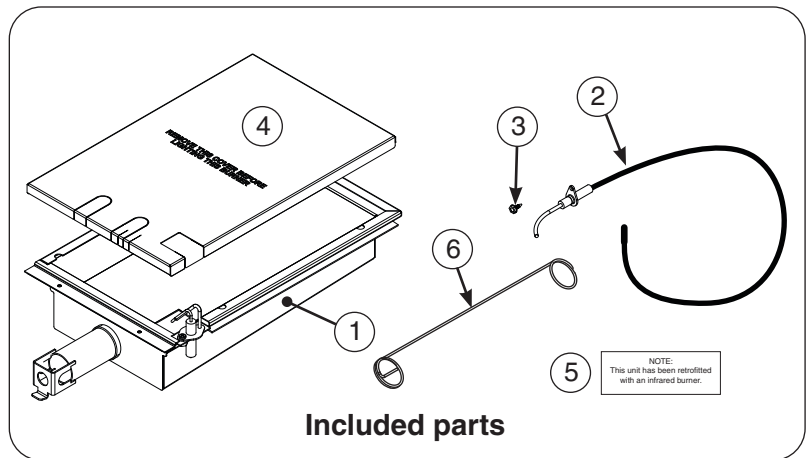

#### PARTS INCLUDED

1. Infrared burner
2. Igniter wire
3. Self-tapping sheet-metal screw
4. Protective burner cover
5. Conversion label
6. Wire extension match holder

#### TOOLS REQUIRED

- Phillips screwdriver
- 9/16" open-end wrench
- 1/4" nut driver or socket wrench

Table 1-1	Infrared Orifice Chart	
	Kit Model #3049	Kit Model #3051
	Grill Models: A530, A660, A790	Grill Models: A430, A540
Natural Orifice	3001-45	3001-49
Propane (L.P.) Orifice	3001-55	3001-56

## INSTALLATION

### REMOVING THE OLD BURNER

1. Be sure the unit is completely cool, the control knobs are turned to the OFF position, the gas supply is shut off, the light switch is off (if applicable), and the power supply is off (if applicable).
2. Open the oven lid.
3. Remove the cooking grid and flavor grid from above the burner. Set the cooking grid aside. **The flavor grid will not be used with the infrared burner, and should be stored away.**
4. Remove the existing main burner by first removing the burner clip (see Fig. 1-1) from under the back of the burner support. Then lift the back of the burner up out of the firebox by grasping the back and pulling upward. Continue to lift the back of the burner up while moving the whole burner back and out so that it pulls away from the forward fire wall opening and the orifice. Retain the clip with the burner so that they can be re-installed in the future, if desired.
5. Remove the lighting tube by removing the two screws with a 1/4"

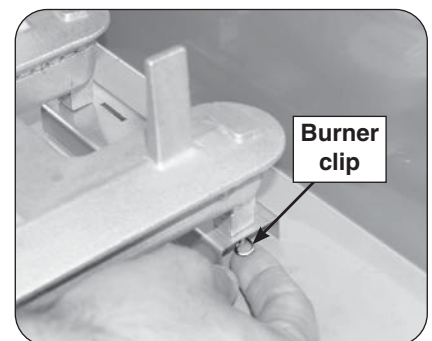

Fig. 1-1 Remove the grids and burner clip

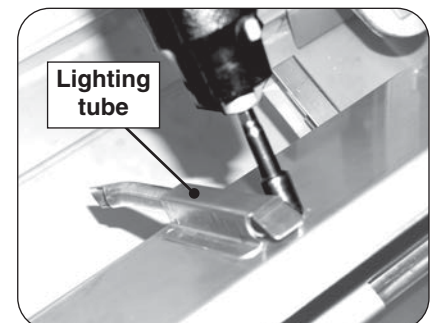

Fig. 1-2 Remove old lighting tube

## INSTALLATION (cont.)

nut driver (see Fig. 2-2).

6. **The grill is equipped with a flame arrester kit for each main burner. This kit is only functional with the standard main burner, and must be removed for proper infrared burner operation.** Use pliers to remove the diverter tube by bending in each side and pulling it outwards (see Fig. 2-1), then reach in and remove the silicone gasket (see Fig. 2-2).
  7. Pull out and completely remove the drip tray from the grill.
  8. With the burner valves in the **OFF** position, pull the valve knobs from their stems. Use a Phillips screwdriver to remove the control panel fastener screws on either side of the grill control panel (see Fig. 2-3). Release the control panel by lifting it slightly and remove it from the grill. Make sure to retain the screws and finish washers for re-attaching the control panel.
- Note:** To protect the wiring harness, carefully lift the control panel away from the frame and let it rest on the attached chain.
9. Lift the heat shield up and inward slightly to clear the diagonal slots hooked over the oven fire wall then pull away from the manifold (see Fig. 2-4).
  10. Remove the existing igniter wire by first sliding the rubber sleeve back off the igniter, then pulling the wire to detach from the igniter. Next remove the igniter nut on the control panel side of the fire wall with a  $\frac{9}{16}$  open-end wrench (see Fig. 2-4) and remove the igniter box from inside the oven. Remove the rubber sleeve from the wire and pull the wire through the heat shield and the insulating tube in the manifold fire wall. Disconnect the other end of the igniter

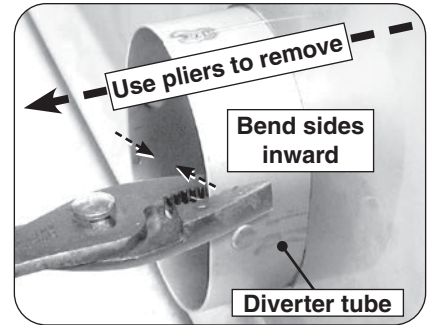

Fig. 2-1 Remove diverter tube

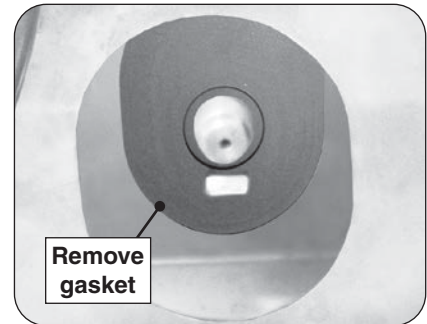

Fig. 2-2 Remove silicone gasket

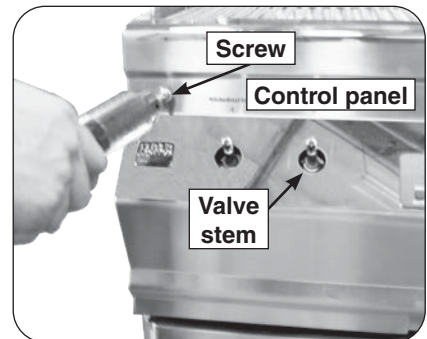

Fig. 2-3 Remove control panel

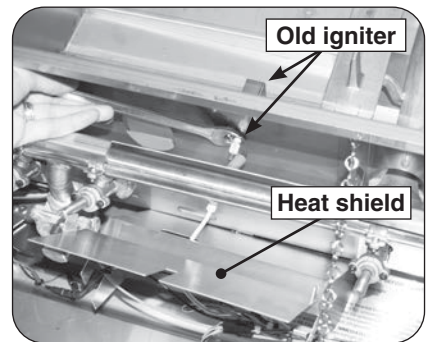

Fig. 2-4 Remove heat shield and old igniter

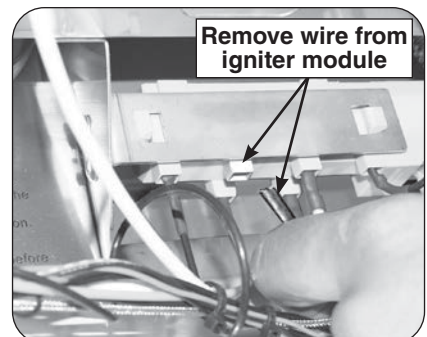

Fig. 2-5 Remove old igniter wire

## INSTALLATION (cont.)

wire from the igniter module (see Fig. 3-5).

### INSTALLING THE NEW INFRARED BURNER

1. Locate the new igniter wire with the insulator attached and thread the wire-end through the hole in the oven fire wall left by the old igniter, from the oven side as shown in Fig. 3-1. Continue to thread the wire end through the insulator tube in the manifold fire wall and through the slot in the heat shield, then route it toward the igniter module on the right. (Hint: wrap around existing wire bundle.)
2. Attach the other end of the new igniter wire (the insulated end) to any male connector on the back of the igniter module (reference Fig. 2-5 on previous page).

**Important:** Test all electrodes for spark before securing the control panel to the frame (see also the section on battery replacement in your owner's manual).

**Note:** The wires can be plugged into any terminal.

3. Attach the insulated portion of the igniter wire to the inside of the oven fire wall by placing the screw (included) through the bracket hole and into the hole in the fire wall (see Fig. 3-1 and Fig. 3-2).
4. Place the new infrared burner gas intake tube in the hole in the oven fire wall and over the orifice fitting, sliding it forward from behind the control panel frame, so the orifice is centered inside the burner gas tube. Set it gently onto the rear burner support, making sure the tabs on the back burner bottom each fit through

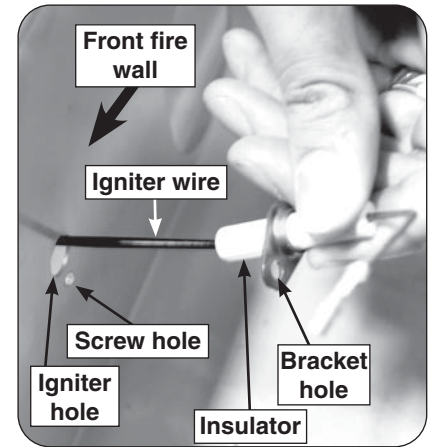

Fig. 3-1 Screw the new wire to the fire wall

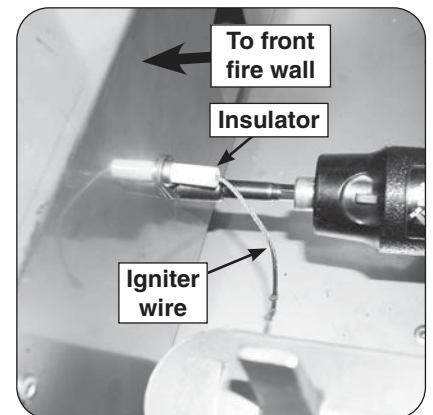

Fig. 3-2 Screw the new wire to the fire wall

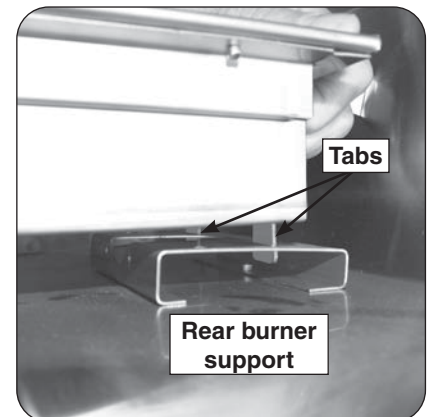

Fig. 3-3 Sliding tabs into support

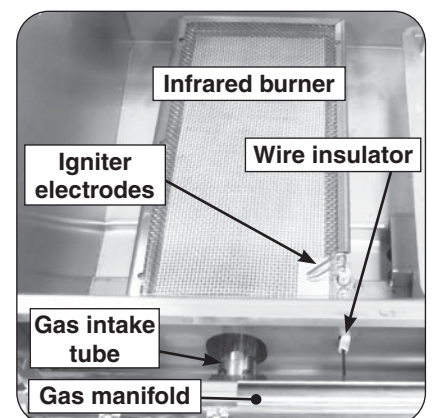

Fig. 3-4 Infrared burner installed

## INSTALLATION (cont.)

their respective slots in the rear burner support. This is critical to the safe function of the grill. (See Fig. 4-3 and Fig. 4-4.)

5. Connect the non-insulated metal end of the igniter wire to the bottom of the igniter electrode assembly at the forward right of the infrared burner (see Fig. 4-1).
6. Apply the conversion label supplied with this kit to the inside of the fire wall behind the control panel so that it does not obscure any other labels (Fig. 4-2).
7. Reposition the heat shield by hooking the diagonal slots back over the sheet metal of the manifold fire wall.
8. Replace the control panel on the frame so the front lip of the control panel hangs from the forward lip of the frame. Re-secure the control panel with the fastener screws.
9. Replace the control knobs.
10. Replace the drip tray.
11. Replace the cooking grid. (DO NOT place the flavor grid on the infrared burner. It is not designed for use on an infrared burner, and should be stored away.)

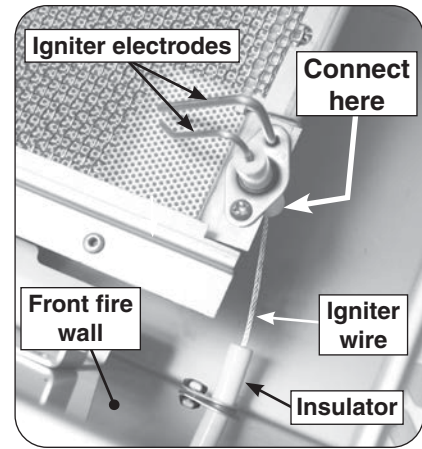

Fig. 4-1 Connect wire to electrode assy.



Fig. 4-2 Apply the conversion label

## INFRARED BURNER OPERATION

The infrared searing burner (optional) cooks with a powerful radiant heat.

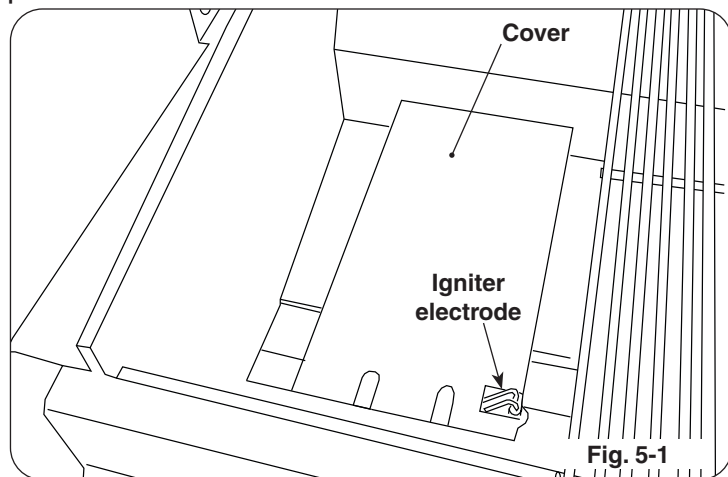

Light the infrared burner following the LIGHTING INSTRUCTIONS found the grill owner's manual or printed on the grill's drip tray. When lighting manually, use the wire extension match holder included with this kit to safely hold a lit match. Follow these guidelines when operating the Infrared burner:

- **DO NOT place food on the cooking grid until the infrared burner glows orange (Fig. 5-3).** Drippings are heated and evaporate instead of sticking to and impairing burner function.
- **For cleaning purposes; always leave your burner on (after cooking) for an additional 5 minutes, to allow for a burnoff period. This is important to keep your burner clean and operating properly. As the burner is self cleaning (at full temperature); avoid the use of cleaners or abrasives.**
- When not in use, **always** cover the infrared burner with the stainless-steel cover. This protects the burner from drippings (from other cooking), water, airborne particles, and foreign objects (Fig. 5-2).

**Important:** Clean burners allow the gas to circulate and burn over the entire heating surface for powerful and even cooking.

- Do not strike or scrape the ceramic portion of the burner as it may chip, crack, or break (Fig. 5-2).

**Note:** Digital thermometer (if equipped) does not give accurate readings for infrared burners.

**Important:** When grilling with the infrared burner, always place a cooking grid above it. The cooking grid must be removed for rotisserie cooking.

**CAUTION:** Never attempt to operate the infrared burner with the protective cover in place.

### WARNING

Only handle the infrared burner cover when the unit is cold or with a well-insulated long-handled tool or heat resistant gloves.

#### SIDE VIEW (with cover on)

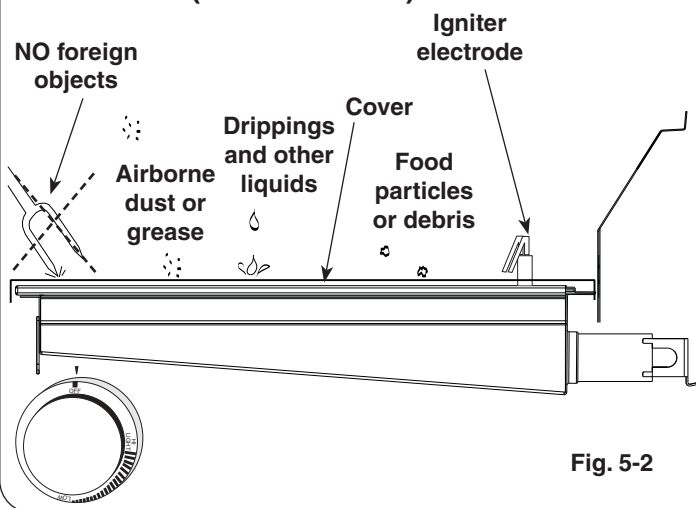

Fig. 5-2

Burner ceramic must be protected with cover when burner is not in use.

#### SIDE VIEW (burner on HI LIGHT and glowing orange)

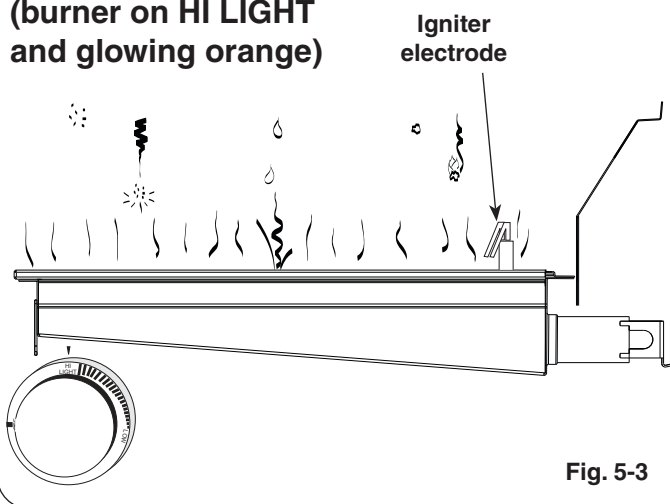

Fig. 5-3

Drips and particles evaporate before hitting infrared burner when cooking at the maximum setting.

**Note:** Flavor grids are not to be used with infrared burners.

To ensure proper operation, all infrared burners (back and main) must be operated on the HI setting for a minimum of 10 minutes. Thereafter, the flame may be lowered as desired.

**CAUTION:** Always monitor the infrared burner flame when operated on low, as it may blow out in high-wind conditions.

---

## NOTES PAGE

---

Please use this page to record any information about your unit that you may want to have at hand.